



# Tre B AV

EVO

Twin twist floor standing pump machine to produce soft ice cream and frozen yogurt.  
**Flavour the Evolution**



Carpigiani innovative EVO technology guarantees versatility and flexibility with excellent production performances

### **New EVO technology**

Innovative refrigeration system allows to obtain a perfect structure result even if the mixes in the two cylinders have different recipes

### **High versatility and flexibility**

Satisfy all customers tastes through the simultaneous production of both traditional soft ice cream and frozen yogurt

### **Overrun and consistency control**

Different consistency control settings for various mix types and easy adjustable overrun



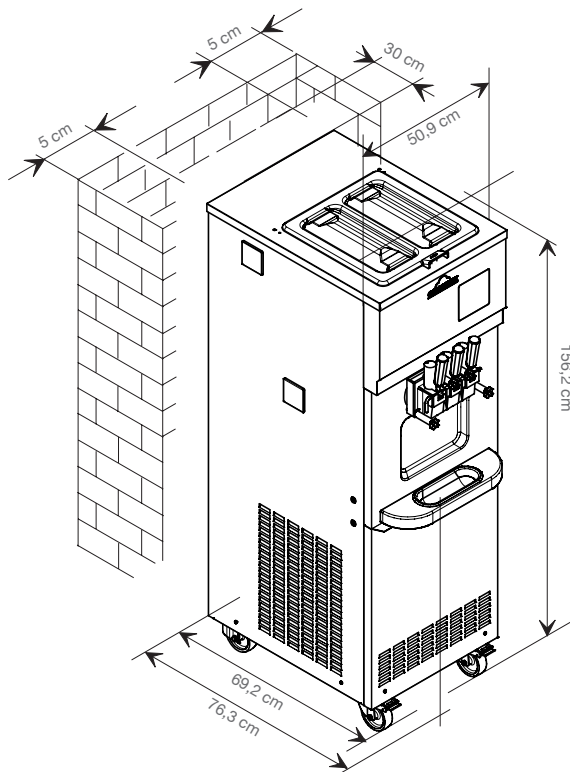

## Optional configurations



### Teorema Remote Control

It gives very important info about the machine, it facilitates the service system and helps the cleaning schedule



### Self closing device

The dispensers close automatically stopping the flow of ice cream, eliminating any waste and preventing mess

	Flavours	Mix Delivery System	Hourly production (75gr portions)	Tank Capacity lt	Cylinder Capacity lt	Nominal Power kW	Fuse Size A	Power Supply	Cooling System	Refrigerant	Net Weight kg
<b>Tre B AV EVO</b>	2 + 1	Pump	480*	10 + 10	1,35	2,7	10	400/50/3**	Air/Water	R404	250

\* production capacity depends on the mix used and the room temperature

\*\* other voltages and cycles available upon request

## Features

## Benefits

Independent refrigeration system and new software	The innovative EVO technology allows to work with different products in the two cylinders
Stainless steel pressurized gear pumps	Ensure the best ice cream texture, quality and high overrun, adjustable from 40% to 80%
Removable pump shaft	For easier cleaning procedures, maximum hygiene and reliability
Interactive display	Communicates with the operator delivering instructions and data regarding machine performance
Tank agitators	Prevent product stratification and helps to reduce foam by maintaining a fluid consistency
Stainless steel beaters	High efficiency beaters with double spirals and idler for a soft and creamy product
Adjustable ice cream flow	Adjustable product flow to meet your specific dispensing speed and volume requirements
Direct expansion cooling cylinders	Optimize refrigeration efficiency for fast freeze downtime, less waste of product ensuring higher quality and energy saving
Defrost system	Possibility to heat the cylinders to simplify the cleaning procedure