



MITO POWER 18  
ESTETICA AESTETIC 02

#### VETRINA GELATO PROFESSIONALE A REFRIGERAZIONE VENTILATA

Vetrine gelato a refrigerazione ventilata con doppio evaporatore alettato e doppia mandata d'aria per una perfetta equalizzazione delle temperature, sbrinamento automatico ad inversione di ciclo. Scocca monolitica coibentata in poliuretano ecologico (HCFC e HFC free) espanso a CO2 con spessore mm 60. Piano espositivo, piano di servizio in acciaio inox finitura lucida, pannello lato operatore in acciaio al carbonio verniciato a polvere, fondo esterno vasca in lamiera preverniciata. Sovrastuttura con montanti in alluminio anodizzato colore argento opposti al lato operatore. Vetri in cristallo temperato. Vetro frontale curvo pirolitico anti-condensa, con apertura verso l'alto servoassistita. Profilo, plafoniera e top in alluminio anodizzato colore argento, illuminazione con doppio neon. Chiusura lato operatore con scorrevoli in policarbonato, rimovibili. Struttura portante e basamento in acciaio al carbonio verniciato a polvere epossidica, con piedini regolabili. Quadro comandi posizionato su lato operatore con centralina elettronica e termometro digitale in vasca, set di regolazione temperatura predisposto per  $-20^{\circ}\text{C}/+2^{\circ}\text{C}$ . Fianchi coibentati laccati con trattamento antigraffio.

#### PROFESSIONAL GELATO CABINETS AT VENTILATED REFRIGERATION

Gelato cabinets with ventilated refrigeration, double finned evaporator and double airflow for a perfect uniformity of temperature. Automatic reverse defrosting cycle. One piece body with ecological polyurethane insulation (HCFC and HFC free), foamed with CO2- 60 mm thick. Display base and service top in bright stainless steel, rear panel in carbon steel, powder painted, external base in painted sheet. Upper structure with silver-colored anodized aluminium supports. Tempered glasses. Front pyrolytic lift-up curved anti fog glass with hydraulic pistons. Profile, complete light heading in silver-colored anodized aluminium; double neon lighting. Operator side closure with pull-out methacrylate sliding doors. Main structure and basement in carbon steel painted with epoxy powder, adjustable feet. Control board on the operator side, electronic board and digital thermometer inside the tank, temperature control set at  $-20^{\circ}\text{C}/+2^{\circ}\text{C}$ . Side panels with insulation and anti-scratch lacquering.

#### MODELLO MODEL

12
16
18
20
24
AI 22.5
AE 22.5
AI 45
AE 45

#### ESTETICHE:

Per scelta **Estetiche Standard disponibili** vedere **pagina 1.034**

#### AESTETICS:

For available **Aesthetics Standard** see **page 1.034**

<ul style="list-style-type: none"> <li>● <b>OPTIONAL</b></li> <li>● <b>VARIANTI EQUIPMENT</b></li> </ul>		Dimensioni (lpxh) Dimensions (lxdh) (mm)	Modello Model
● Portaconi completo bianco	White cone holder		
● Lavaporzionatore con rubinetto e consolle portaoggetti DX	Scoop washer, water tap, consolle DX		
● Lavaporzionatore con rubinetto e consolle portaoggetti SX	Scoop washer, water tap, consolle SX		
● Kit targhette gusti	Kit labels flavours		12
			16
			18
			20
			24
			AI - AE
● Vassoio inox V5 2 vaschette lt 5	Stainless Steel tray V5 2 containers lt 5	330x330x100H	
● Vassoio inox V6 3 vaschette lt 5	Stainless Steel tray V6 3 containers lt 5	495x330x100H	
● Kit Vassoio inox V7 (3+3)	Stainless Steel tray kit container V7 (3+3)		AE 45
● Kit Vassoio inox V8 (3+3)	Stainless Steel tray kit container V8 (3+3)		AI 45
● Kit Vassoio inox V9 (3+3)	Stainless Steel tray kit container V9 (3+3)		AE 22.5
● Kit Vassoio inox V10 (3+3)	Stainless Steel tray kit container V10 (3+3)		AI 22.5
● Kit tubazioni per Unità Condensatrici Remote (UCR) - al metro lineare	Piping kit for Remote Condensing Unit (UCR) - each meter		
● Kit distanziali inox per vaschette (lt 5, 10, 12)	Stainless steel support kit container (lt 5, 10, 12)		16
			20
● Kit distanziali inox per vaschette (lt 5, 10)	Stainless steel support kit container (lt 5, 10)		AE 45
			AI 45
			AI - AE 22.5
● Kit distanziali inox per vaschette trapezoidali	Stainless steel support kit trapezoidal container		AI - AE 45
● Kit ruote movimentazione vetrina	Wheel kit for easy handling		

● **OPTIONAL** **KIT VASCHETTE INOX**  
STAINLESS STEEL CONTAINERS KIT

Dimensioni (lxpxh) Dimensions (lxdxh) (mm)	Litri Liters	Modello Model	Quantità Quantity
--	-----------------	------------------	----------------------

● 360 x 165 x 120H	5	12	12
		16	16
		18	18
		20	20
		24	24
		AI 45	12
		AE 45	12
		AI 22.5	14
		AE 22.5	14

● 360 x 165 x 150H	7	12	12
		16	16
		18	18
		20	20
		24	24
		AI 45	12
		AE 45	12
		AI 22.5	14
		AE 22.5	14

● **OPTIONAL** **KIT VASCHETTE INOX**  
STAINLESS STEEL CONTAINERS KIT

Dimensioni (lxpxh) Dimensions (lxdxh) (mm)	Litri Liters	Modello Model	Quantità Quantity
--	-----------------	------------------	----------------------

● 360 x 250 x 80H	5	12	8
		16	10
		18	12
		20	12
		24	16
		AI 45	7
		AE 45	7
		AI 22.5	9
		AE 22.5	9

● 360 x 250 x 120H	10	12	8
		16	10
		18	12
		20	12
		24	16
		AI 45	7
		AE 45	7
		AI 22.5	9
		AE 22.5	9

● 360 x 250 x 150H	12	12	8
		16	10
		18	12
		20	12
		24	16
		AI 45	7
		AE 45	7
		AI 22.5	9
		AE 22.5	9

● 360 x 185 x 120H	5	AI 45	14
		AE 45	14

**TRAPEZOIDALI**

**COMPONIBILITA VASCHE VASCA ESPOSIZIONE**  
**DISPLAY CONTAINERS ARRANGEMENT**

lt 5 (360x165x120H)    lt 7 (360x165x150H)

12	16	18	20	24

lt 5 (360x250x80H)    lt 10 (360x250x120H)    lt 12 (360x250x150H)

8	10	12	12	16

**AI 45    AE 45    AI 22.5    AE 22.5**

lt 5 (360x165x120H)    lt 7 (360x165x150H)

12	12	14	14

lt 5 (360x250x80H)    lt 10 (360x250x120H)    lt 12 (360x250x150H)

7	7	9	9

lt 5 (360x185x120H) **TRAPEZOIDALI**

14	14

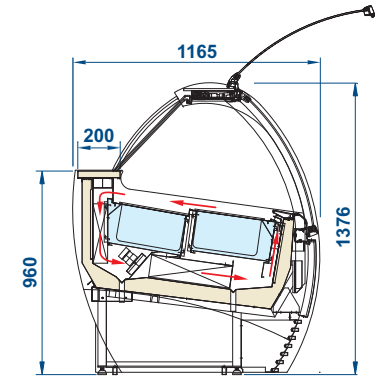

**MITO POWER**  
12, 16, 18, 20, 24

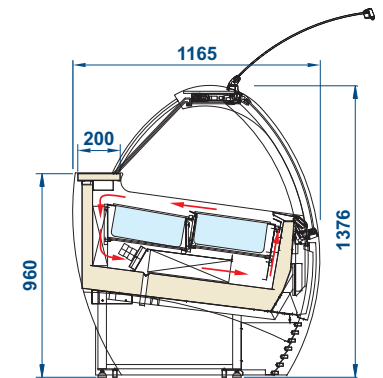

**MITO POWER**  
AE, AI

CARATTERISTICHE TECNICHE TECHNICAL FEATURES		
Dimensioni esterne (lpxh)	External dimensions (lxdxh)	mm
Refrigerazione	Refrigeration	
Capacità' (lorda-netta)	Capacity (gross - net)	lt
Temperatura di regolazione	Cabinet capacity range	°C
Temperatura prodotto	Product temperature	°C
Sbrinamento	Defrost	
Classe climatica	Climatic class	N°
Condizioni ambientali	Operating conditions	°C / %RH
Compressore (Tipo - n°)	Compressor (type - n°)	
Alimentazione	Power supply	V / ph / Hz
Assorbimento elettrico (regime)	Electrical input (standard)	W / A
Assorbimento elettrico (sbrinamento)	Electrical input (defrost)	W / A
Peso netto	Net weight	kg

12	16	18	20	24
RV	RV	RV	RV	RV
<b>1100 x 1168 x 1376</b>	<b>1440 x 1168 x 1376</b>	<b>1600 x 1168 x 1376</b>	<b>1770 x 1168 x 1376</b>	<b>2120 x 1168 x 1376</b>
<b>Ventilata</b> Ventilated	<b>Ventilata</b> Ventilated	<b>Ventilata</b> Ventilated	<b>Ventilata</b> Ventilated	<b>Ventilata</b> Ventilated
<b>715 / 54</b>	<b>948 / 112</b>	<b>1064 / 126</b>	<b>1181 / 140</b>	<b>1414 / 168</b>
<b>-20 / +2</b>	<b>-20 / +2</b>	<b>-20 / +2</b>	<b>-20 / +2</b>	<b>-20 / +2</b>
<b>-16 / -14</b>	<b>-16 / -14</b>	<b>-16 / -14</b>	<b>-16 / -14</b>	<b>-16 / -14</b>
<b>Inversione Ciclo</b> Reverse Cycle	<b>Inversione Ciclo</b> Reverse Cycle	<b>Inversione Ciclo</b> Reverse Cycle	<b>Inversione Ciclo</b> Reverse Cycle	<b>Inversione Ciclo</b> Reverse Cycle
<b>4+</b>	<b>4+</b>	<b>4+</b>	<b>4+</b>	<b>4+</b>
<b>35 / 70</b>	<b>35 / 70</b>	<b>35 / 70</b>	<b>35 / 70</b>	<b>35 / 70</b>
<b>Ermetico</b> Hermetic (1)	<b>Ermetico</b> Hermetic (2)	<b>Ermetico</b> Hermetic (2)	<b>Ermetico</b> Hermetic (2)	<b>Ermetico</b> Hermetic (2)
<b>230 / 1 / 50</b>	<b>230 / 1 / 50</b>	<b>230 / 1 / 50</b>	<b>230 / 1 / 50</b>	<b>230 / 1 / 50</b>
<b>1240 / 6</b>	<b>1510 / 7</b>	<b>1510 / 7</b>	<b>2300 / 11</b>	<b>2350 / 11</b>
<b>2300 / 11</b>	<b>2560 / 12</b>	<b>2560 / 12</b>	<b>3890 / 19</b>	<b>4000 / 19</b>
<b>235</b>	<b>320</b>	<b>345</b>	<b>365</b>	<b>455</b>

**Modelli con unità condensatrici a bordo con condensazione ad aria**  
Models with condensing unit included with air cooled

CARATTERISTICHE TECNICHE TECHNICAL FEATURES		
Dimensioni esterne (lpxh)	External dimensions (lxdxh)	mm
Refrigerazione	Refrigeration	
Capacità' (lorda-netta)	Capacity (gross - net)	lt
Temperatura di regolazione	Cabinet capacity range	°C
Temperatura prodotto	Product temperature	°C
Sbrinamento	Defrost	
Classe climatica	Climatic class	N°
Condizioni ambientali	Operating conditions	°C / %RH
Compressore (Tipo - n°)	Compressor (type - n°)	
Alimentazione	Power supply	V / ph / Hz
Assorbimento elettrico (regime)	Electrical input (standard)	W / A
Assorbimento elettrico (sbrinamento)	Electrical input (defrost)	W / A
Peso netto	Net weight	kg

AI 45	AE 45	AI 22.5	AE 22.5
RV	RV	RV	RV
<b>1727 x 1168 x 1376</b>	<b>1717 x 1168 x 1376</b>	<b>1634 x 1168 x 1376</b>	<b>1595 x 1168 x 1376</b>
<b>Ventilata</b> Ventilated	<b>Ventilata</b> Ventilated	<b>Ventilata</b> Ventilated	<b>Ventilata</b> Ventilated
<b>440 / 110</b>	<b>440 / 110</b>	<b>513 / 128</b>	<b>513 / 128</b>
<b>-20 / +2</b>	<b>-20 / +2</b>	<b>-20 / +2</b>	<b>-20 / +2</b>
<b>-16 / -14</b>	<b>-16 / -14</b>	<b>-16 / -14</b>	<b>-16 / -14</b>
<b>Inversione Ciclo</b> Reverse Cycle	<b>Inversione Ciclo</b> Reverse Cycle	<b>Inversione Ciclo</b> Reverse Cycle	<b>Inversione Ciclo</b> Reverse Cycle
<b>4+</b>	<b>4+</b>	<b>4+</b>	<b>4+</b>
<b>35 / 70</b>	<b>35 / 70</b>	<b>35 / 70</b>	<b>35 / 70</b>
<b>Ermetico</b> Hermetic (1)	<b>Ermetico</b> Hermetic (1)	<b>Ermetico</b> Hermetic (2)	<b>Ermetico</b> Hermetic (2)
<b>230 / 1 / 50</b>	<b>230 / 1 / 50</b>	<b>230 / 1 / 50</b>	<b>230 / 1 / 50</b>
<b>1240 / 6</b>	<b>1240 / 6</b>	<b>1510 / 7</b>	<b>1510 / 7</b>
<b>2300 / 11</b>	<b>2300 / 11</b>	<b>2560 / 12</b>	<b>2560 / 12</b>
<b>350</b>	<b>350</b>	<b>350</b>	<b>350</b>

**Modelli con unità condensatrici a bordo con condensazione ad aria**  
Models with condensing unit included with air cooled