



MILLENNIUM SP 18

Pannello frontale PM_AD1 - Fianchi estetici GRIGIO E_Z065

Front panel PM_AD1 - Side panels GRIGIO E_Z065

PANNELLO FRONTALE:

Per scelta **Tipo**, **Colori Disponibili Standard** vedere sezione 4

FRONT PANEL:

For available **Front Panels** and **Standard Colours** see section 4

FIANCHI ESTETICI:

Colori disponibili standard - Finiture laccate

SIDE PANELS:

Available standard colours - Lacquered finishes



Grigio
E_Z065

VETRINA GELATO PROFESSIONALE A REFRIGERAZIONE VENTILATA

Vetrine Gelato a refrigerazione ventilata con evaporatore alettato e sbrinamento automatico ad inversione di ciclo. Scocca monolitica coibentata in poliuretano ecologico (HCFC e HFC free) espanso a CO2 con spessore mm 60. Piano espositivo e piano di servizio in acciaio inox finitura lucida, pannello lato operatore in lamiera plastificata, fondo esterno vasca in lamiera preverniciata. Fianchi esterni estetici in stratificato. Sovrastruttura con montanti laterali in acciaio al carbonio verniciati a polvere epossidica, colore nero. Vetri in cristallo temprato. Vetro frontale curvo pirolitico anti-condensa, con apertura verso l'alto servoassistita. Profilo plafoniera in alluminio anodizzato colore argento, illuminazione con 1 neon. Chiusura lato operatore con tendina autoavvolgente. Struttura e basamento in acciaio al carbonio verniciato a polvere epossidica, con piedini regolabili. Quadro comandi posizionato su lato operatore con centralina elettronica e termometro digitale in vasca, set di regolazione della temperatura predisposto per **-20°C + 2°C**.

PROFESSIONAL GELATO CABINETS AT VENTILATED REFRIGERATION

Gelato cabinets with ventilated refrigeration, finned evaporator and automatic reverse defrosting cycle. One piece body with ecological polyurethane insulation (HCFC and HFC free), foamed with Co2 60 mm thick. Display base and service top in bright stainless steel, rear panel in plastified sheet, external base in painted sheet. Upper structure with lateral profiles in carbon steel painted with epoxy powder, black colour. External stratified side panels. Tempered glass structure. Front pyrolytic lift-up curved anti-fog glass with hydraulic pistons. Profile, complete light heading in silver-colored anodized aluminium, neon lighting. Operator side closure with self-rolling curtain. Main structure and basement in carbon steel painted with epoxy powder, adjustable feet. Control board on the operator side with electronic board and digital thermometer inside the tank, temperature control set at **-20°C/+2°C**. Side panels in compact grade standard and anti-scratch lacquering.

MODELLO MODEL

SP 12

SP 16

SP 18

SP 20

SP 24

SP 12+12

● OPTIONAL		Dimensioni (lpxh) Dimensions (lxdxh) (mm)
● Portaconi completo bianco	White cone holder	
● Lavaporzionatore con rubinetto e consolle portaoggetti DX	Scoop washer, water tap, consolle DX	
● Lavaporzionatore con rubinetto e consolle portaoggetti SX	Scoop washer, water tap, consolle SX	
● Vassoio inox V1 2x2 vaschette lt 5	Stainless Steel tray V1 2x2 lt 5	330x690x100H
● Vassoio inox V2 2x3 vaschette lt 5	Stainless Steel tray V2 2x3 lt 5	495x690x100H
● Kit ruote movimentazione vetrina	Wheel kit for easy handling	
● Kit tubazioni per Unità Condensatrici Remote (UCR) - al metro lineare	Piping kit for Remote Condensing Unit (UCR) - each meter	

● OPTIONAL KIT VASCHE TTE INOX STAINLESS STEEL CONTAINERS KIT			
Dimensioni (lxpxh) Dimensions (lxdxh) (mm)	Litri Liters	Modello Model	Quantità Quantity

● 360 x 165 x 120H 	5	12	12
		16	16
		18	18
		20	20
		24	24
		12+12	24

● 360 x 165 x 150H 	7	12	12
		16	16
		18	18
		20	20
		24	24
		12+12	24

● OPTIONAL KIT VASCHE TTE INOX STAINLESS STEEL CONTAINERS KIT			
Dimensioni (lxpxh) Dimensions (lxdxh) (mm)	Litri Liters	Modello Model	Quantità Quantity

● 360 x 250 x 80H 	5	12	8
		16	10
		18	12
		20	12
		24	16
		12+12	16

● 360 x 250 x 120H 	10	12	8
		16	10
		18	12
		20	12
		24	16
		12+12	16

● 360 x 250 x 150H 	12	12	8
		16	10
		18	12
		20	12
		24	16
		12+12	16

■ AREE PERSONALIZZABILI: Frontale
Customizable Front area

MILLENNIUM SP 12

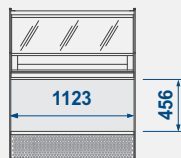

MILLENNIUM SP 16

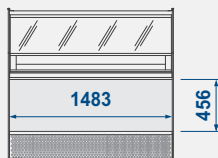

MILLENNIUM SP 18

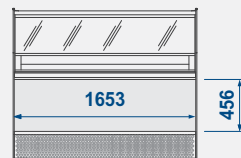

MILLENNIUM SP 20

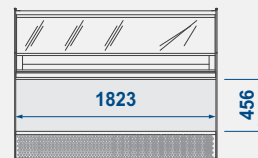

MILLENNIUM SP 24 / 12+12

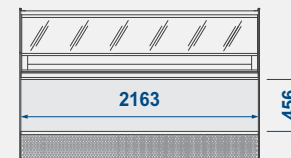

COMPONIBILITÀ VASCHE VASCA ESPOSIZIONE DISPLAY CONTAINERS ARRANGEMENT			12	16	18	20	24	12+12
lt 5 (360x165x120H)	lt 7 (360x165x150H)		12	16	18	20	24	12 (+12)
lt 5 (360x250x80H)	lt 10 (360x250x120H)	lt 12 (360x250x150H)	8	10	12	12	16	8 (+8)

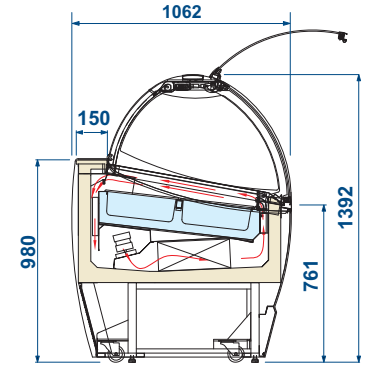

CARATTERISTICHE TECNICHE TECHNICAL FEATURES		
Dimensioni esterne (lxdpxh)	External dimensions (lxdpxh)	mm
Refrigerazione	Refrigeration	
Capacità (lorda-netta)	Capacity (gross - net)	lt
Temperatura di regolazione	Cabinet capacity range	°C
Temperatura prodotto	Product temperature	°C
Sbrinamento	Defrost	
Classe climatica	Climatic class	N°
Condizioni ambientali	Operating conditions	°C / %RH
Compressore (Tipo - n°)	Compressor (type - n°)	
Alimentazione	Power supply	V / ph / Hz
Assorbimento elettrico (regime)	Electrical input (standard)	W / A
Assorbimento elettrico (sbrinamento)	Electrical input (defrost)	W / A
Peso netto	Net weight	kg

SP 12	SP 16	SP 18	SP 20	SP 24	SP 12+12
RV	RV	RV	RV	RV	RV
1148 x 1062 x 1392	1508 x 1062 x 1392	1678 x 1062 x 1392	1848 x 1062 x 1392	2188 x 1062 x 1392	2188 x 1062 x 1392
Ventilata Ventilated	Ventilata Ventilated	Ventilata Ventilated	Ventilata Ventilated	Ventilata Ventilated	Ventilata Ventilated
630 / 118	870 / 160	970 / 181	1080 / 201	1300 / 241	1300 / 241
-20 / +2	-20 / +2	-20 / +2	-20 / +2	-20 / +2	-20 / +2
-16 / -14	-16 / -14	-16 / -14	-16 / -14	-16 / -14	-16 / -14
Inversione Ciclo Reverse Cycle	Inversione Ciclo Reverse Cycle	Inversione Ciclo Reverse Cycle	Inversione Ciclo Reverse Cycle	Inversione Ciclo Reverse Cycle	Inversione Ciclo Reverse Cycle
4+	4+	4+	4+	4+	4+
35 / 70	35 / 70	35 / 70	35 / 70	35 / 70	35 / 70
Ermetico Hermetic (1)	Ermetico Hermetic (2)	Ermetico Hermetic (2)	Ermetico Hermetic (2)	Ermetico Hermetic (2)	Ermetico Hermetic (2)
230 / 1 / 50	230 / 1 / 50	230 / 1 / 50	230 / 1 / 50	230 / 1 / 50	230 / 1 / 50
1650 / 7.8	1950 / 8.8	2000 / 8.9	2400 / 11	3140 / 15	2850 / 14
3500 / 15.6	3990 / 18	4020 / 18	5000 / 20.2	5050 / 20.5	5900 / 25
235	303	330	348	437	470