



#### VETRINA GELATO PROMOZIONALE A REFRIGERAZIONE VENTILATA

Carrettino dei gelati a refrigerazione ventilata con evaporatore alettato e sbrinamento automatico a gas caldo. Scocca monolitica coibentata con poliuretano ecologico (HCFC e HFC free) espanso a CO<sub>2</sub>. Interno vasca e piano di servizio in acciaio inox. Esterno vasca in acciaio al carbonio verniciato a polvere epossidica con serigrafia decorativa su tutto il perimetro. Esterno fondo vasca in lamiera preverniciata. Sovrastuttura in cristallo temperato, con vetro frontale dritto. La chiusura lato operatore avviene tramite ribaltina. Tenda decorativa parasole con sostegni laterali in acciaio al carbonio. Unità condensatrice ermetica a bordo con quadro comandi elettronico. Struttura in acciaio al carbonio verniciato a polvere, con 2 ruote a raggi e ruotino pivotante. Maniglia in acciaio inox tubolare per facilitare la movimentazione. La vetrina può contenere un doppio livello di vaschette H120.

#### PROMOTIONAL ICE-CREAM CABINETS AT VENTILATED REFRIGERATION

Ice cream trolley with ventilated refrigeration, finned evaporator and automatic hot gas defrosting. One piece body with ecological polyurethane insulation (HCFC and HFC free), foamed with CO<sub>2</sub>. Internal tank and service top in stainless steel. External tank in carbon steel with serigraphies. External base in painted sheet. Tempered glass structure. Curved straight front glass. Closure on the operator side with methacrylate sliding doors. Sun curtain with side supports in tubular stainless steel. Built-in hermetic condensing unit with electronic control board. Main structure in carbon steel painted with powder, 2 ray wheels and one pivoting wheel. Handle in tubular stainless steel for an easier handling. This cabinet can be fitted with a double level of ice-cream containers H120.

MODELLO  
MODEL

#### IL CARRETTINO DEI GELATI

#### ● OPTIONAL

- Kit supporto vaschette lt 4.75
- Support kit containers lt 4.75

## COMPONIBILITÀ VASCHE VASCA ESPOSIZIONE DISPLAY CONTAINERS ARRANGEMENT

lt 5  
(360x165x120H)

**Doppia fila di riserva**  
Piled up double row



6 (+6)



lt 4.75  
(260x157x170H)



10



## ● OPTIONAL KIT VASCHE INOX STAINLESS STEEL CONTAINERS KIT

Dimensioni (lxpxh) Dimensions (lxdxh) (mm)	Litri Liters	Quantità Quantity
--	-----------------	----------------------

● 360 x 165 x 120H 5 6



● 260 x 157 x 170H 4.75 10



## CARATTERISTICHE TECNICHE TECHNICAL FEATURES

Dimensioni esterne (lxpxh)	External dimensions (lxdxh)	mm
Refrigerazione	Refrigeration	
Capacità (lorda-netta)	Capacity (gross - net)	lt
Temperatura prodotto	Product temperature	°C
Sbrinamento	Defrost	
Classe climatica	Climatic class	N°
Condizioni ambientali	Operating conditions	°C / %RH
Compressore (Tipo - n°)	Compressor (type - n°)	
Alimentazione	Power supply	V / ph / Hz
Assorbimento elettrico (regime)	Electrical input (standard)	W / A
Assorbimento elettrico (sbrinamento)	Electrical input (defrost)	W / A
Peso netto	Net weight	kg

## IL CARRETTINO

RV

**1970 x 1250 x 2081**

**Ventilata** Ventilated

**260 / 104**

**-16 / -14**

**Gas Caldo** Hot Gas

**4**

**30 / 55**

**Ermetico** Hermetic (1)

**230 / 1 / 50**

**500 / 2.8**

**1200 / 5.9**

**205**

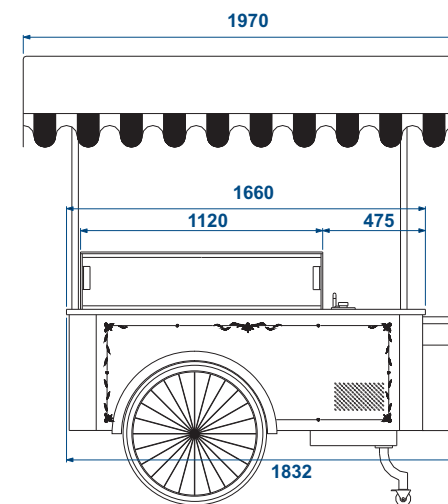
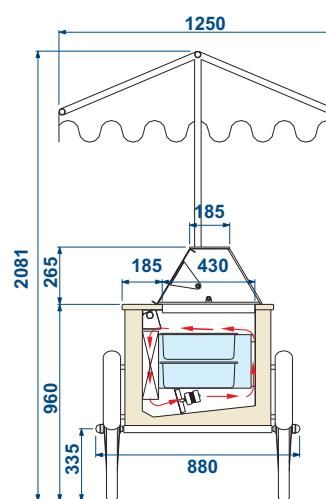

1.011

Modelli con unità condensatrici a bordo con condensazione ad aria  
Models with condensing unit included with air cooled